

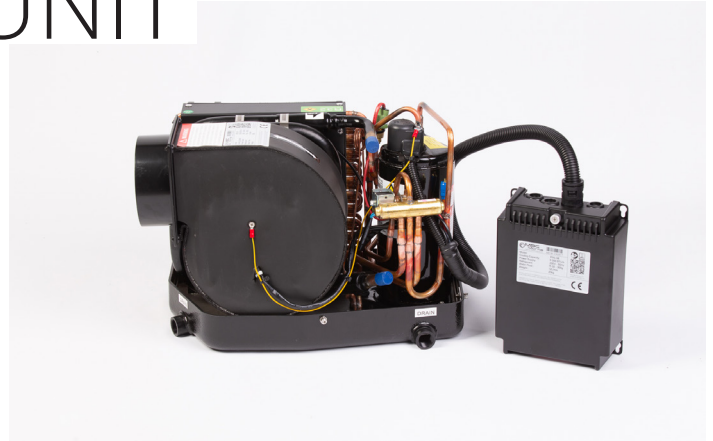

INSTALLATION AND USER MANUAL FOR SSC-ESC-SCP UNITS

EN

ESC UNIT



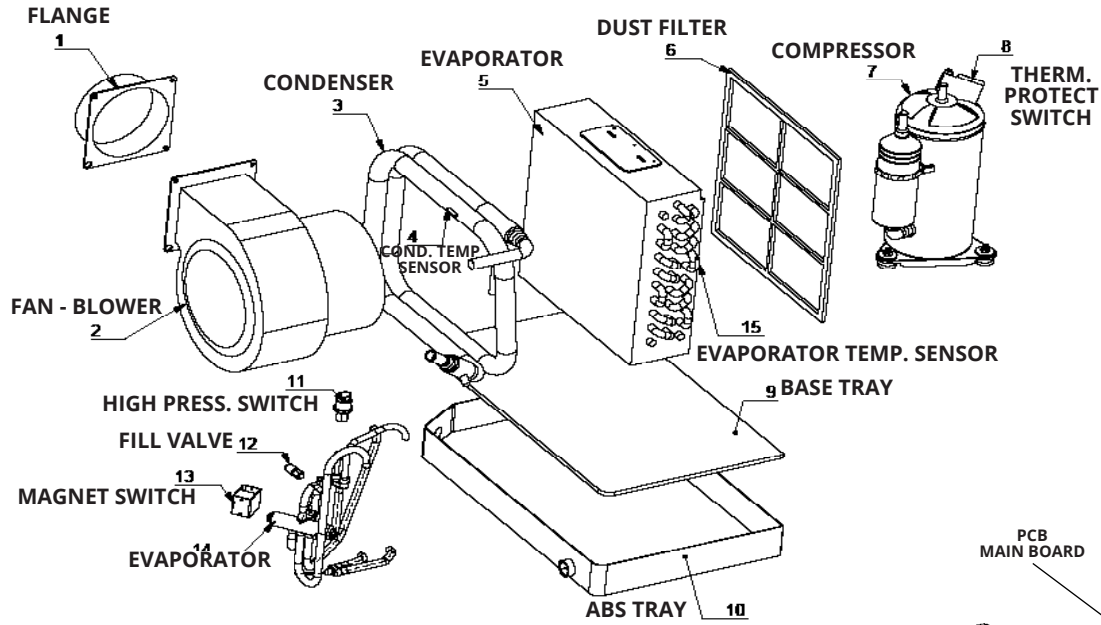

EXPLODED DRAW FROM ESC UNIT

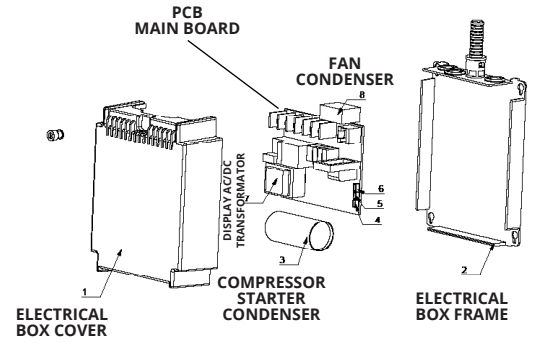

SCP SPLIT UNIT



THANK YOU FOR CHOOSING MBC MARINE PRODUCT!

Before starting the installation, make sure that the shipping box and the air conditioner are intact. DO NOT use a broken or damaged product.

Package Contents – Check After Unboxing

Make sure the package includes the following components:

- 1 air conditioning unit
- 1 display
- 1 LAN data cable (5 meters) – for connecting the controller
- 1 temperature sensor – for AI1 socket
- 4 L-shaped mounting brackets – for securing the unit

If any item is missing or damaged, do not begin the installation – contact your distributor or MBC Marine representative.

EXPLANATION OF SYMBOLS:



ATTENTION!!

Ignoring this information may cause material damage and may have adverse impact to the operation of this product.



WARNING!

Safety information: Ignoring these instructions could result in death or serious injury.



CAUTION!

Safety information: Ignoring this instruction can cause serious injury.

WARNING:



Installation of the system should only be carried out by qualified personnel with appropriate knowledge. The following information is intended for technicians who are familiar with applicable guidelines and relevant safety regulations and precautions. For warranty professional and proper installation specifications are essential. If you do not have the necessary knowledge, entrust the installation to a specialist! It is important to use the appliance only for its intended purpose and in compliance with the relevant regulations.

INTRODUCTION

Welcome to MBC Marine Systems
What's Included in the Package

PART 1 SAFETY AND FIRE PROTECTION WARNINGS

- 1.1 Safety Information
- 1.2 Fire Protection Warning
- 1.3 Safety Warning
- 1.4 Electrical Shock Warning

PART 2 INSTALLATION GUIDE

- 2.1. Purpose of This Manual
- 2.2 System Operation Logic
- 2.3 Conceptual Warning for all Installers
- 2.4 Selecting a Suitable Installation Location

PART 3 Unit Placement and First Steps Before Installing

- 3.1 General Placement Guidelines
- 3.2 Mounting
- 3.3 Typical Installation
- 3.4 Installing Display
- 3.5 Installing the Room Temperature Sensor
- 3.6 Condensate Drainage

PART 4 AIR SYSTEM INSTALLATION

- 4.1 Return Air
- 4.2 Blower Rotation
- 4.3 Supply Air System

PART 5 SEA WATER SYSTEM

- 5.1 Sea Water Intake
- 5.2 Sea Water Pump and Strainer
- 5.3 Sea Water Pipe
- 5.4 Checklist for Correct Sea Water System
- 5.5 Galvanic Corrosion Protection

PART 6 POWER SUPPLY

- 6.1 Electrical Requirements for Safe Operation
- 6.2 Electrical Connection Checklist

PART 7 WIRING DIAGRAM

- 7.1 Terminal Connections Overview of ESC unit
- 7.2 Wiring Connect for ESC unit
- 7.3 ESC unit electrical box
- 7.4 Terminal Connections overview of SCP unit

- 7.5 SCP unit electrical box
- 7.6 SCP unit electrical scheme
- 7.7 SCP-M MULTI SPLIT system electrical wiring
- 7.9 Soft Starter wiring
- 7.8 Soft Starter
- 7.10 Soft Starter connection wiring
- 7.11 DIP Switch

PART 8 DISPLAY

- 8.1 Functions and Settings

PART 9 TROUBLESHOOTING

- 9.1 Understanding Error Codes
- 9.2 ERROR 1 Room Temperature Sensor Error
- 9.3 ERROR 2 Evaporator Temperature Error
- 9.4 ERROR 3 Condenser Temperature Error
- 9.5 ERROR 4 Overheated Evaporator Protection
- 9.6 ERROR 5 Refrigerant Leak Malfunction
- 9.7 ERROR 6 Compressor Overheating
- 9.8 ERROR 8 High Gas Temperature Error
- 9.9 ERROR 9 Evaporator Temperature Protection (DEFROSTING)
- 9.10 ERROR 10 Sea Water Temperature Protection
- 9.11 ERROR 11 Incorrect Connection
- 9.12 ERROR 12 Compressor Overcurrent Error
- 9.15 ERROR 15 Communication Failure

PART 11 KEY INSTALLATION NOTES

PART 10 WARRANTY

- 10.1 Warranty Limited
- 10.2 Warranty Period
- 10.3 Product Registration
- 10.4 Warranty Exclusions
- 10.5 Final Provisions

PART 12 TECHNICAL DATA OF ESC - SCP UNITS

PART 13 LEGAL DISCLAIMERS AND LIABILITY

PART 1. SAFETY AND FIRE PROTECTION WARNINGS



1.1 SAFETY INFORMATION:

The manufacturer assumes no liability for damage to the device in the following cases:

- Installation or connection failure
- Damage to the product due to mechanical impact and over voltage
- Modification of the product without the express written permission of the manufacturer
- Unusual use, differing from standards



1.2 FIRE PROTECTION WARNING:

Installation and maintenance of the unit may be dangerous due to pressurized copper pipes and electrical equipment. When working on the unit, always take the safety precautions into account and wear protective goggles during installation, use work gloves and place a fire extinguisher near the work area!



1.3 SAFETY WARNING:

It is strictly forbidden to install the air conditioning unit in a place where it is possible for the equipment to deliver carbon monoxide, harmful gas of the engine or any other toxic substance inside the boat.



1.4 ELECTRICAL SHOCK WARNING:

There are components of the unit that are powered by 230 V AC during operation. If the device is connected to a power source, disconnect the power supply at the main switchboard or at the power source before opening the electric box. Failure to do so may result in personal injury or even death!

To minimise the risk of electric shock and personal injury, ground the equipment properly! The equipment meets the relevant fire protection requirements. The device must not be installed in premises where petrol engines, tanks, LPG / CPG cylinders, regulators, valves, fuel lines or connectors can be found!

PART 2. INSTALLATION GUIDE

2.1 PURPOSE OF THIS MANUAL

This manual provides guidance for the proper installation and operation of MBC Marine ESC series 230V self-contained direct expansion marine air conditioning systems. Its purpose is to offer installers and maintenance personnel detailed, step-by-step, clear, and practical support throughout the entire lifecycle of the system – from installation to troubleshooting and maintenance.

2.2 SYSTEM OPERATING LOGIC

This unit is based on the balance of three key subsystems:

1. Seawater Circuit – Responsible for cooling the heat exchanger. Without proper water flow, the compressor will overheat.
2. Airside Circuit – Ensures the circulation of cooled or heated air. Insufficient airflow may cause the evaporator to freeze, overheat, or result in poor comfort levels.
3. Electrical System – Covers voltage and current supply, communication, and safety circuits. Faults in this system may damage the electronics or prevent the unit from starting.

2.3 CONCEPTUAL WARNING FOR ALL INSTALLERS:

No two boats or installations are the same. Do not copy the installation of another boat – the correct setup is determined by the physical characteristics of the specific vessel.

The system will only operate properly if all components – water, air, and electrical – are installed professionally and according to specifications.

Most common issues are not caused by the unit itself but by installation deficiencies: incorrect tilt angle, poor ventilation, clogged filter, improper ducting, etc.

Proper installation, as detailed in this manual, is a requirement for the warranty to be valid.



WARNING!

Start the installation only if the location of each unit complies with the relevant regulations. At planning, make sure that there is enough space for subsequent installation and maintenance work.

PART 3. UNIT PLACEMENT AND FIRST STEPS BEFORE INSTALLING

2.4 SELECTING A SUITABLE INSTALLATION LOCATION

Choosing the right placement for the system is critical. Before the installation consider the following guidelines:

Requirements:

- A dry, well-ventilated enclosed space
- Minimum 60 mm clearance from surrounding furniture (on all sides)
- A stable, level surface, preferably with a slight 1–2 cm slope to allow condensate drainage
- Easily accessible for maintenance
- Isolated from heat sources and exhaust gases

Avoid the Following Locations:

- Engine room or machinery space
- Directly next to ventilation ducts
- Wet or damp floor areas
- In the path of exhaust fumes or carbon monoxide
- Poorly ventilated enclosed compartments

3.1 General Placement Guidelines

- Install the unit on a stable, horizontal surface.
- Provide a slight tilt of 1–2 cm towards the condensate drain.
- Do not enclose the unit in a tight compartment! Ensure at least 60 mm of free space around it for proper airflow.
- Position the compressor as far as possible from the air intake opening to minimize noise.
- Choose the unit's location so that the electrical box can also be mounted securely on a dry, well-ventilated surface
- Ensure the air filter remains accessible for future maintenance – do not install the unit inside closed furniture or in areas that are difficult to disassemble.

3.2 Mounting

Use the 4 metal brackets provided in the package, and secure the unit along the edge of the tray firmly, but not too tightly.



SAFETY WARNING!

Do not install the air conditioner in the bilge or engine compartment of the boat and make sure that the selected place is properly blocked from gases and vapours coming from these

PLACEMENT OF THE AIR-CONDITIONING UNIT

3.3 TYPICAL INSTALLATION:

See the picture below for the installation of a self-contained air conditioner unit.

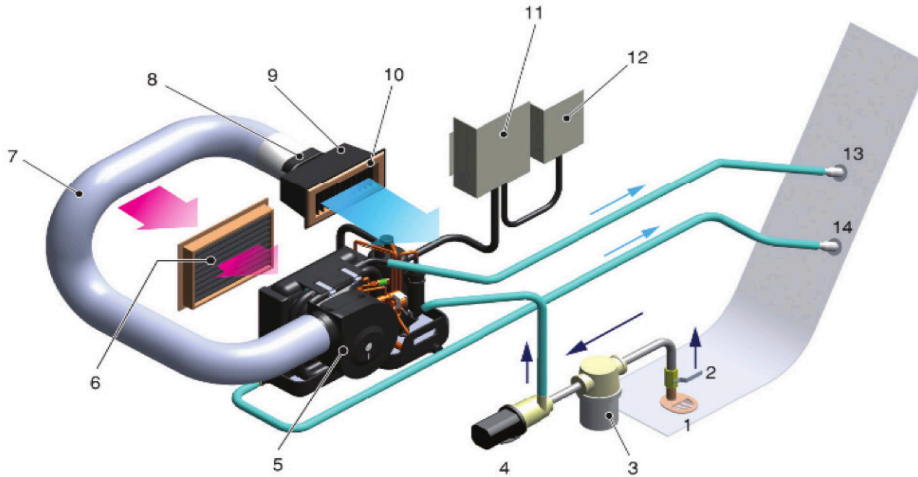

1. Scoop Type Thru-Hull
2. Ball Valve
3. Sea Water Strainer
4. Sea Water Pump
5. A/C unit
6. Return Air Grille
7. Flexible Duct
8. Duct Ring
9. Transition Box
10. Supply Air Grille
11. Control Box
12. Soft Starter (optional)
13. Sea Water Outlet
14. Drain Outlet

3.4 INSTALLING DISPLAY (CD-3 Type)

Before installing the display, observe the following guidelines:

Install the control panel only on a surface located higher than the centerline of the cabin, in a location protected from both external and internal sources of heat and light.

Do not install the display in locations where it may be exposed to:

- Direct sunlight
- Nearby heat-producing appliances or device
- Partition walls with potential heat accumulation behind the panel
- Directly above or below air intake or outlet vents
- Ensure that the display is easily accessible for operation

3.5 INSTALLING THE ROOM TEMPERATURE SENSOR

Although the display includes a built-in thermostat, always use the included room temperature sensor with a 5-meter cable, as it provides more accurate readings of the cabin temperature.

Connect the temperature sensor to the PCB's A1 (white) slot.

3.6 CONDENSATE DRAINAGE

The unit produces condensate during COOLING mode, which is collected in the unit's drain pan. The installation location of the marine A/C unit must ensure that proper condensate drainage is always possible.

The water collected in the drain pan must be discharged through a drain pipe into the bilge of the boat, ideally close to the automatic bilge pump.

If the unit is installed in a location where direct drainage into the bilge is not possible, the condensate must be collected and pumped out using a dedicated drain pump.



WARNING!

When installing a drain pump, do not connect its outlet to the discharge line of any other system.



WARNING!

Do not direct the drain pipe to any area of the boat where water cannot be properly collected or pumped out. Always route the condensate drain towards the bilge, close to an automatic bilge pump.

PART 4. AIR SYSTEM INSTALLATION

4.1. RETURN AIR

During operation, the air conditioning unit draws in room air through the return side, where it passes over the evaporator coil and is then discharged cooled (or heated) through the supply side. The volume and quality of the return air have a direct impact on the unit's cooling/heating performance and safe operation.

Choosing the correct size for the return grille is essential. If the grille is too small, the fan cannot circulate enough air, which may cause the evaporator to overcool and freeze. This can result in cooling failure, an error code (e.g., Error 9), or compressor overload. The minimum grille size required for each unit type must always be verified in the technical specifications table.

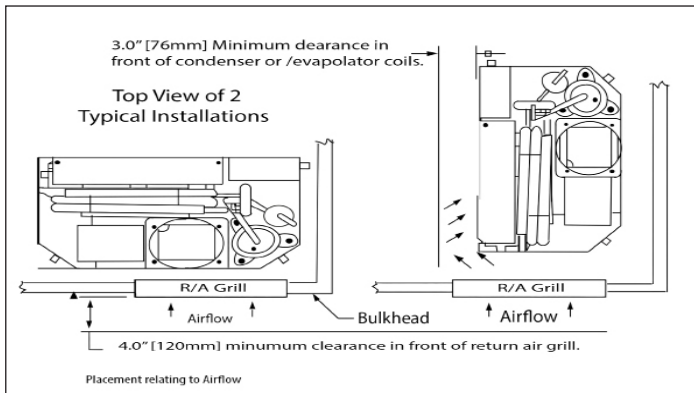

4.2 BLOWER ROTATION

Before installation (if necessary) set the fan in the direction which allows the most direct airflow through the air pipes. The air outlet direction of the unit's fan can be adjusted horizontally or vertically. Adjust the air outlet position by loosening the fixing screw and tightly fasten the fixing screw after positioning the outlet to the optimum position. See Figure 3.

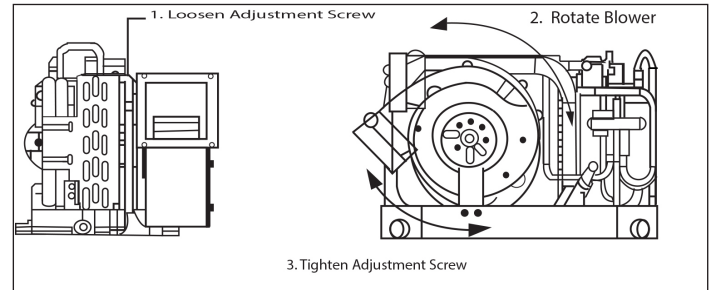

WARNING!

Lack of air supply leads to malfunction or even failure of the unit!

4.3 SUPPLY AIR SYSTEM

Supply air is the cooled or heated air that enters the cabin after passing through the evaporator.

Supply grilles should always be installed as high as possible in the cabin, since cold air naturally sinks and warm air rises. When adjusting the direction of the grille louvers, make sure the air is not directed toward the return grille, as this can create a short air cycle.

The most common mistake on the supply side is restricting the airflow – for example, using undersized grilles, closed louvers, or overly narrow branches. In such cases, the unit essentially “chokes,” the fan is unable to push air through the system, and the unit becomes overloaded. This may cause the evaporator to freeze in cooling mode (Error 9), or the compressor to overheat in heating mode (Error 4).

The supply duct must always be made of thermal and acoustic insulated ducting, suitable for the unit’s output capacity. The duct diameter must never be reduced below the manufacturer’s specifications – for example, a 150 mm outlet must not be reduced to 100 mm. The system is highly sensitive to reduced airflow: even a 30–40% loss can cause performance issues and trigger error codes.

The total duct length should not exceed 4 meters. Avoid 90° or sharp bends, as they can reduce airflow by up to 25%.

Ducts must be installed tightly and without creases, ensuring they are not compressed later by furniture or structural components.



WARNING!

The air outlet must not be directed towards the air intake as short circulating cycles can lead to a loss of performance!

PART 5. SEA WATER SYSTEM

The sea water cooling circuit is responsible for dissipating heat from the condenser of the ESC unit, making its proper operation essential. Any malfunction or insufficient water flow can lead to compressor overheating, the appearance of error codes (e.g., Error 6, Error 12), and even complete system shutdown.

When designing the seawater system, it is critical to ensure an unobstructed, continuous, and air-free water flow. Every component along the water path – thru-hull fitting, ball valve, strainer, pump, and piping – must be installed precisely and in the correct order. Improper sequencing or height differences can cause air pockets, vibration, or suction problems.

5.1. SEA WATER INTAKE

The sea water intake (scoop-type thru-hull fitting) must be positioned on the lower part of the hull, preferably near the keel. The deeper it is placed, the cooler the seawater the system can draw in – which is especially important in warm climates. The ball valve must be connected directly to the intake over a short distance, followed by the strainer, then the pump, and finally the inlet to the A/C unit's condenser.

5.2. SEA WATER PUMP AND STRAINER

The circulating pump (magnetic driven pump) and the seawater strainer must always be installed below the waterline, at least 30–50 cm lower, to allow the system to be gravity-filled with water. This ensures air-free pump operation and reliable water delivery.



WARNING!

MBC Marine is not responsible for any malfunctions resulting from improper installation or operation of the seawater pump.

The sea water pump will only function properly if the water line is free of air pockets, does not contain negative loops, high points, or sharp bends, and if the hoses rise continuously and evenly to the condenser inlet of the unit.

The system must be completely leak-free, and all suction-side components (thru-hull fitting, strainer, pump) must be airtight.

The sea water outlet must be installed above the waterline, but no more than 150 mm above it. If the outlet is placed too close to the intake, the system may draw in its own heated water, significantly reducing cooling efficiency. The minimum distance between the sea water inlet and outlet must therefore be 150 cm.

5.3. SEA WATER PIPE

Only spiral-reinforced, pressure-resistant hoses should be used for the water system. These hoses must not collapse when bent and must maintain their full internal flow diameter. Damaged, kinked, overly long, or improperly routed hose sections can result in reduced water flow, overheating, compressor overload, or error codes.

5.4. CHECKLIST FOR CORRECT SEA WATER SYSTEM

The system is only considered properly installed if the following conditions are met:

- All connections and threads are sealed with appropriate marine-grade sealing materials (e.g., Loctite 55 or Sika 291i).
- The ball valve is fully operable and easily accessible.
- The seawater strainer is installed in an easily accessible location, and its transparent housing is intact and not degraded.
- The suction side is completely airtight, and the water hose rises continuously, allowing air bubbles to escape naturally.
- All metal parts in contact with seawater – including the intake fitting, pump, and A/C tray – are connected to the boat's central bonding system.
- The system includes a built-in zinc or aluminum sacrificial anode for galvanic protection of the condenser and pump.

- Before starting the seawater system, always check for leak-free connections, a clean strainer, and verify that the pump delivers sufficient water flow to the unit.

SAFETY NOTICE!



Do not operate the system without a water strainer! Running the system without a strainer will result in water pump failure and may ultimately lead to complete system failure.

The seawater circuit must be able to be shut off during malfunction or maintenance. Failure to install a ball valve is considered a safety hazard and may pose a life-threatening risk.

5.5. GALVANIC CORROSION AND PROTECTION

All metal parts in contact with seawater — including the inlet fitting, pump, and A/C tray must be connected to the boat's grounding system. A sacrificial anode should be installed before the pump to protect the system from corrosion.



WARNING! MBC Marine assumes no liability for any damage caused by electrolysis or corrosion if no sacrificial anode or grounding protection is installed in the system.



SAFETY NOTICE!

If you do not have sufficient training to install the water system of the unit consult a qualified boat technician. In saltwater environment - in case of longer stops - it is recommended to remove seawater from the system.

Follow the guidelines below to properly install the water system of the marine air conditioner unit. See pictures below:

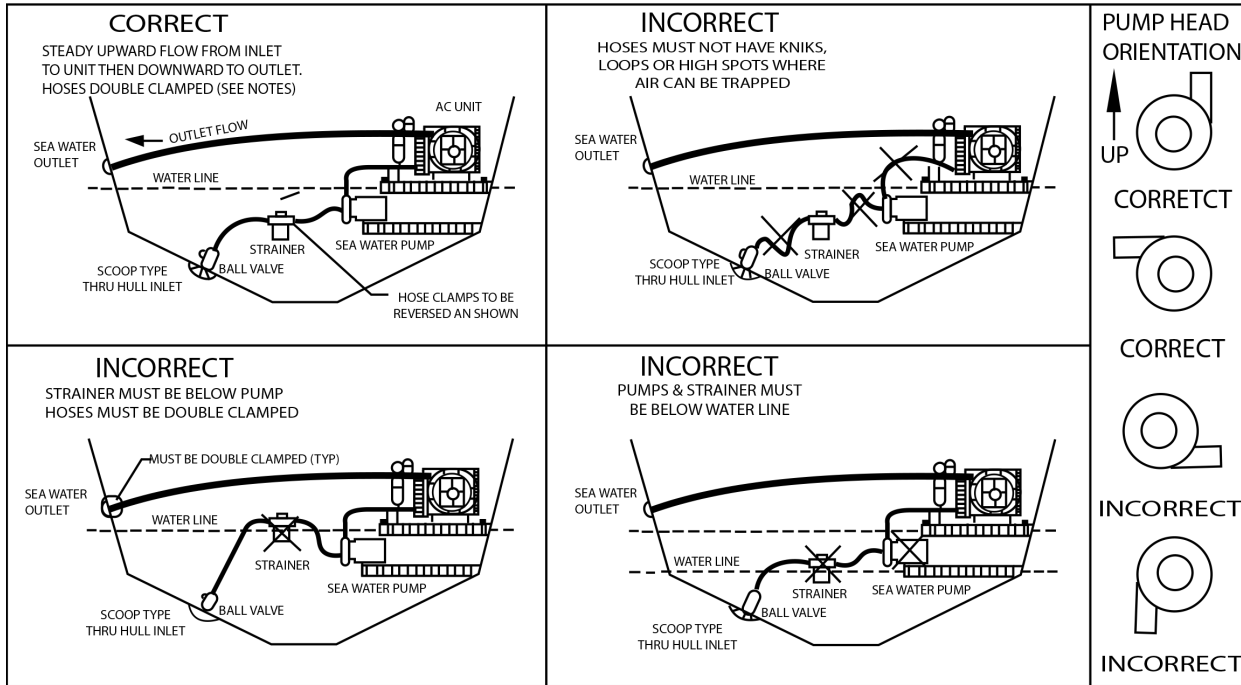

PART 6. POWER SUPPLY

6.1. ELECTRICAL REQUIREMENTS FOR SAFE OPERATION

ESC units operate on 1Ph 230V / 50Hz power. The current draw depends on the unit type (see technical specifications), but the following are always required:

Proper cable cross-section (minimum 3x1.5–2.5 mm², depending on model)

A dedicated circuit breaker for the unit only

A 30 mA residual current device (RCD) for personal safety

Grounding of the system is mandatory. The yellow-green wire must always be used as the protective earth and must never be used for any other purpose (e.g., neutral).



WARNING!

Undersized wiring or loose connections can cause overheating, contact failures, and may lead to damage of the control board or compressor.



WARNING!

Cable ends must be fitted with ferrules when connecting to the terminal block.

6.2. ELECTRICAL CONNECTION CHECKLIST

- The power supply is 230V and stable.
- Cable cross-sections are appropriate.
- The 230V **shore power phase** wire is connected to terminal **L1**.
- The 230V **shore power neutral** wire is connected to terminal **L0**.
- The 230V **pump phase** wire is connected to terminal **P1**.
- The 230V **pump neutral** wire is connected to terminal **P0**.
- Ground wires for both shore power and pump are connected to the grounding point.
- All connections are tight and undamaged.
- Grounding is connected at the terminal block for both pump and shore power.
- Circuit breaker and RCD (FI relay) are installed.
- The electrical box is located in a well-ventilated area.
- The display is operational and communicates with the controller.
- The temperature sensor is connected (AI1).

PART 7. WIRING DIAGRAM 230V UNITS

7.2 WIRING CONNECT FOR ESC UNIT

7.1 TERMINAL CONNECTIONS OVERVIEW ESC

WIRING CONNECTIONS FOR ESC UNIT

- **HEAT:** **Not used** – leave unconnected.
- **PI:** Seawater pump **PHASE** output
- **L1:** Shore power **PHASE** input
- **L0:** Shore power **NEUTRAL** input
- **PO:** Seawater Pump **NEUTRAL** output
- **E:** **GROUND** - Mandatory for safety.

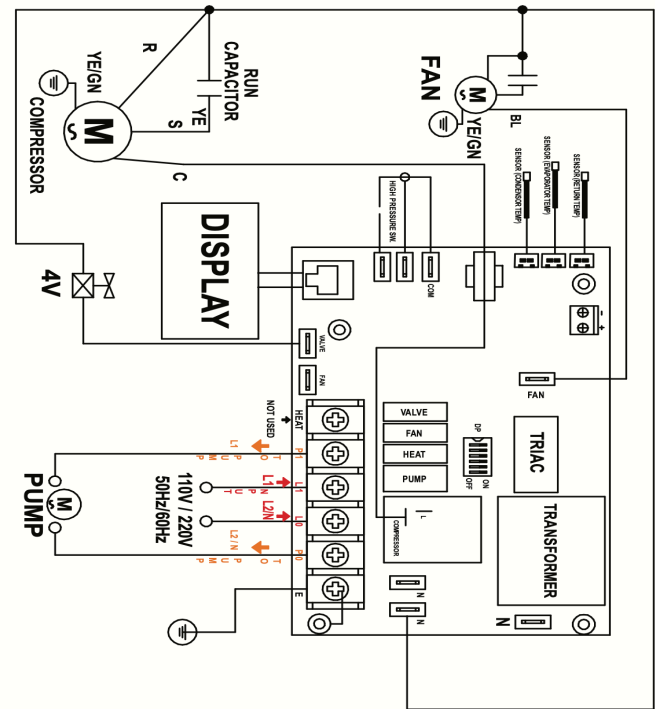

7.3 ESC UNIT ELECTRICAL BOX

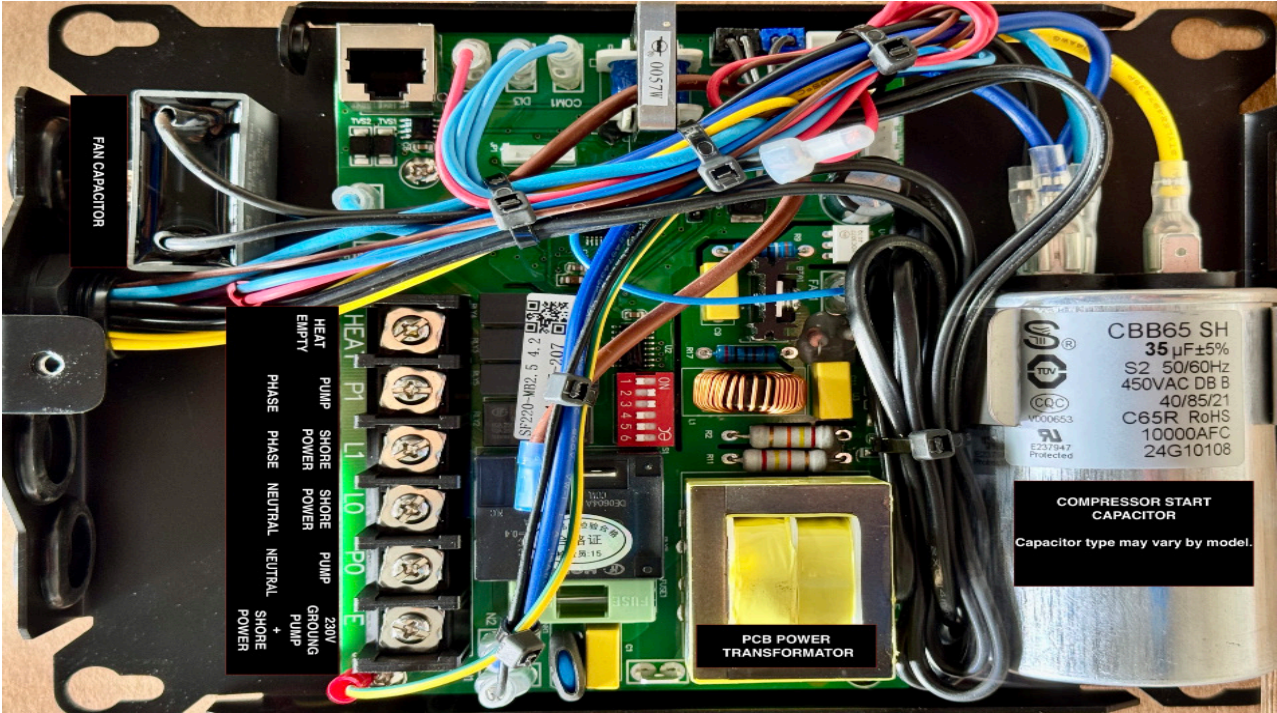

7.4 TERMINAL CONNECTIONS OVERVIEW OF SCP SYSTEM

WIRING CONNECTIONS FOR SCP UNIT

- **HEAT:** **Not used** – leave unconnected.
- **P1:** Seawater pump **PHASE** output
- **L1:** Shore power **PHASE** input
- **L0:** Shore power **NEUTRAL** input
- **PO:** Seawater Pump **NEUTRAL** output
- **E:** **GROUND** - Mandatory for safety.

This section describes how to connect the SCP evaporator unit to the control PCB located inside the electrical control box. Before starting the installation, ensure that the system power supply is completely disconnected.

Connect the evaporator fan electrical wires as follows:

- Evaporator phase (brown wire) Connect to FAN terminal on PCB
- Evaporator neutral (blue wire) Connect to LO terminal
- Evaporator earth (green-yellow wire) - Connect to E terminal

The phase supply for the evaporator fan is controlled by the PCB and will activate automatically when the system starts operating.

7.5 SCP UNIT ELECTRICAL BOX

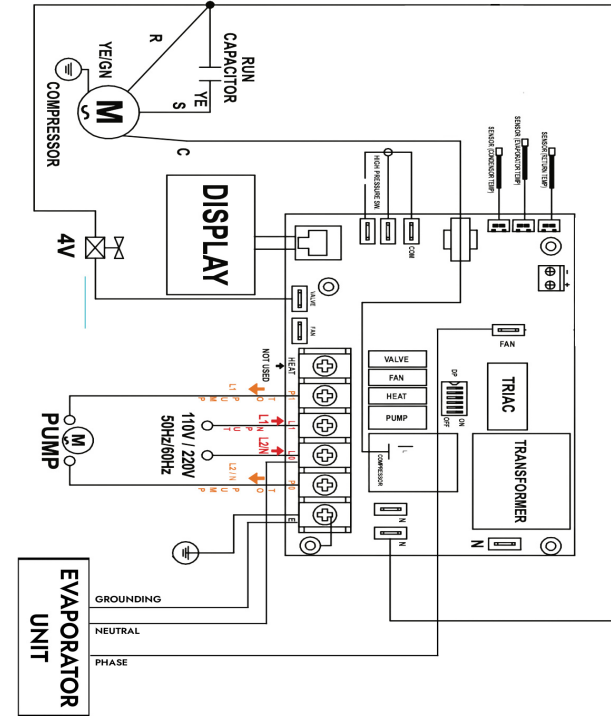

7.6 SCP - SPLIT SYSTEM ELECTRICAL WIRING SCHEME



7.7 SCP-M - MULTI SPLIT SYSTEM ELECTRICAL WIRING

SCP - SPLIT WITH 2 EVAPORATORS

In a Multi Split configuration, the second evaporator must be connected in parallel with the first evaporator unit. Both evaporators share the same electrical connection points on the control PCB.

Connect the evaporators fan electrical wires as follows:

Evaporator 1 and 2 phase (brown wire)

- Connect to FAN terminal on PCB

Evaporator 1 and 2 neutral (blue wire) Connect to LO terminal

- Evaporator 1 and 2 earth (green-yellow wire) - Connect to E terminal

The phase supply for the evaporator fans is controlled by the PCB and will activate automatically when the system starts operating.

Important Notice – Fan Control

The SCP-M system uses one single display/controller for both evaporator units.

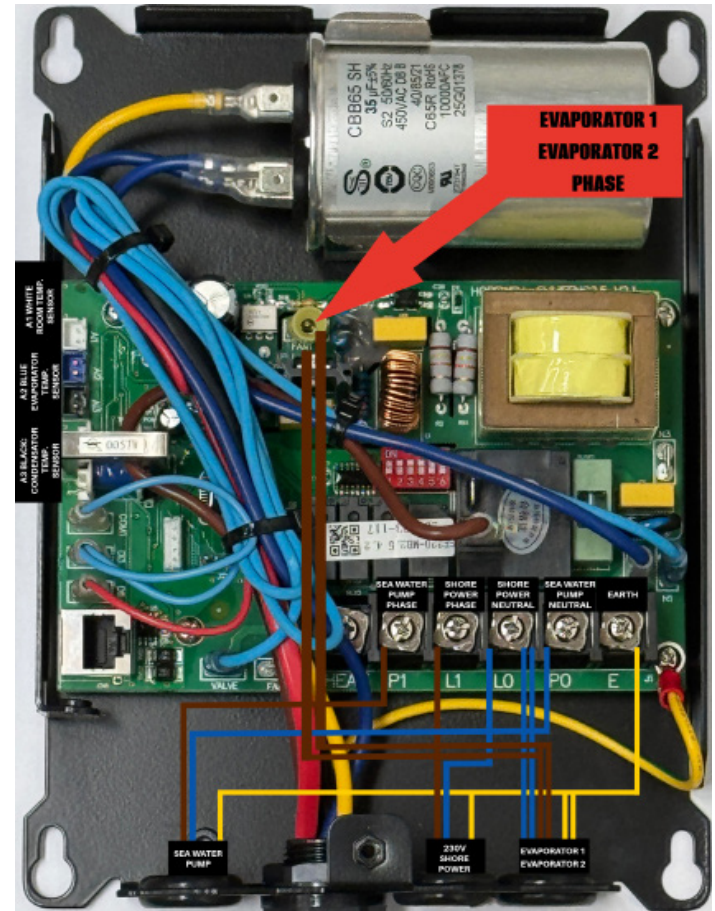

7.8 SOFT STARTER

The purpose of a soft starter is to reduce inrush current during startup, especially when starting the compressor or the sea-water pump. Its use is recommended whenever the vessel's power supply is unstable or limited.

It is particularly recommended when:

- The air conditioner is powered by a generator
- The boat is docked at a marina with weak shore power
- The system is sensitive to sudden current surges (e.g., small fuses, undersized cables)
- The soft starter gradually increases the voltage supplied to the compressor, preventing current spikes, reducing the risk of tripping breakers, and extending the system's lifespan.

7.9 SOFT STARTER WIRING

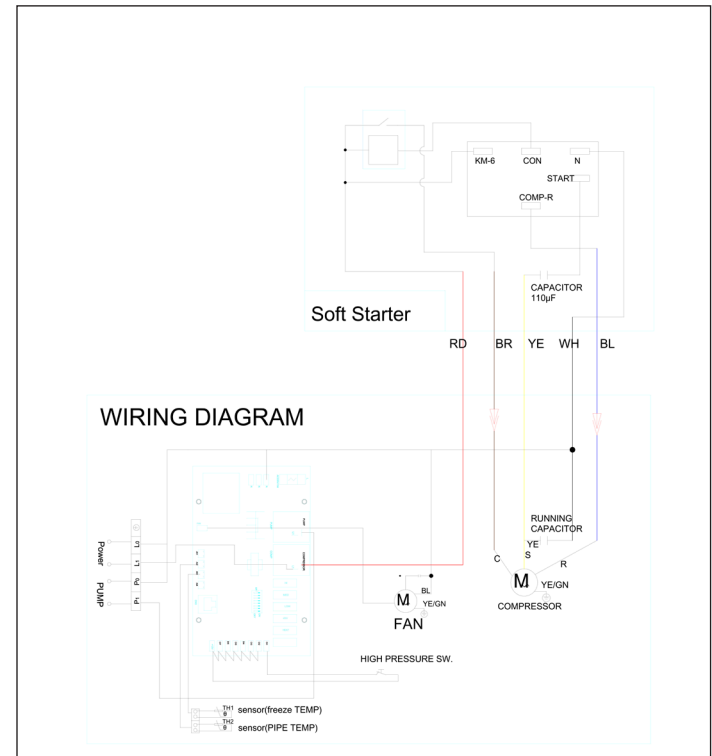

7.10 SOFT STARTER CONNECTION LAYOUT.

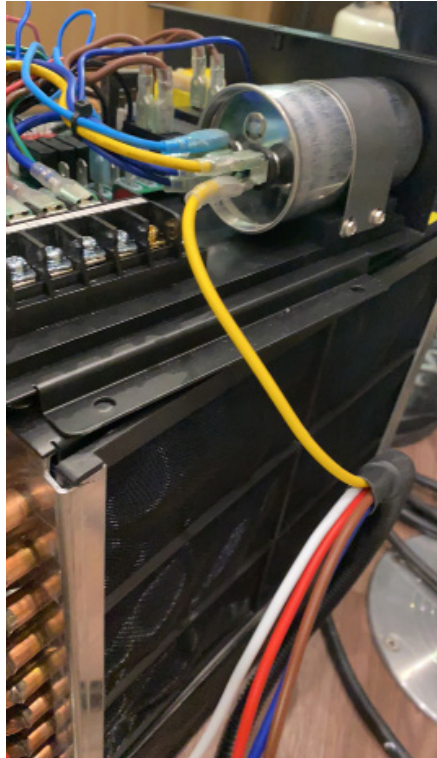

1.



2.



3.



4.



5.



6.

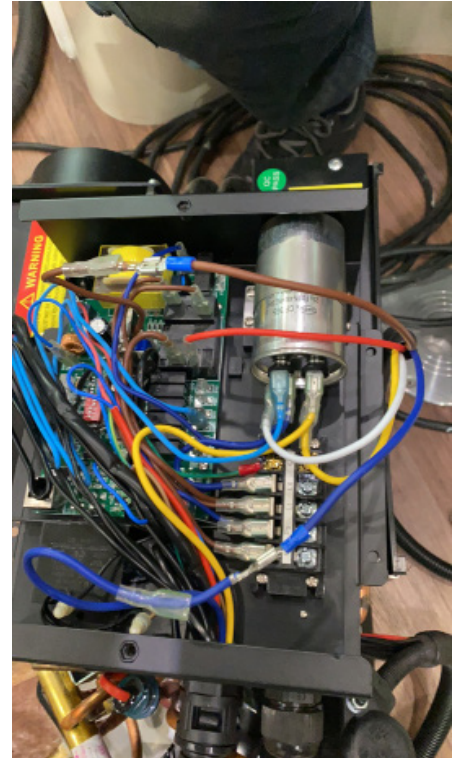

7.

7.11 DIP SWITCH SETTINGS ESC - SCP

DIP switches are used to configure key operational modes of the unit, such as cooling/heating settings, pump behavior, and sensor logic. Correct switch positioning is essential for proper and safe system operation. Please refer to the descriptions below before changing any factory settings.

Factory default configuration on ESC - SSC :

SW1: OFF
 SW2: ON
 SW3: ON
 SW4: OFF
 SW5: OFF
 SW6: OFF

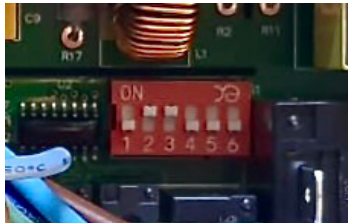

Changing these settings without proper understanding may result in malfunction or reduced performance.

SW1 + SW2 – Operation Mode Selection:

SW1 OFF + SW2 OFF – Cooling and heating mode with electric heating
 SW1 OFF + SW2 ON – Cooling and heating mode only
 SW1 ON + SW2 OFF – Cooling mode with electric heating
 SW1 ON + SW2 ON – Cooling mode only

SW3 – Power-On State After Power Failure:

1 – Restores last operating state (memory)
 0 – Remains shut down after power failure

SW4 – Sensor Functions:

ON – Disables evaporator and condenser sensor functions
 OFF – Sensors remain active

SW5 – Seawater Pump Operation:

ON – Pump switches on/off together with the compressor
 OFF – Pump runs continuously after startup

SW6 – Ventilation Mode:

ON – Ventilation mode is available
 OFF – No ventilation mode

Factory default configuration on SCP:

SW1: OFF
 SW2: ON
 SW3: ON
 SW4: ON
 SW5: OFF
 SW6: OFF

PART 8 DISPLAY

The control panel of the MBC marine air conditioning systems is equipped with an intuitive display that provides real-time information about various operational parameters of the system. The data displayed allows users to easily monitor the system's status and performance, as well as quickly make any necessary adjustments.

MBC Marine ESC and SCP units are equipped with an LED display. The DC-3 display is included in the standard package.



The unit is in sleep mode.

Tap the screen to access the main display.

This screen appears immediately after the unit is powered on.



WARNING!

Wait at least 10 seconds to switch between each mode because the coolant flowing in the system needs time to return to the normal pressure volume.

8.1 FUNCTIONS AND SETTINGS

This screen is the default control interface of the MBC Marine air conditioning system. It allows the user to set the temperature, select the operating mode, adjust the fan speed, and access both the menu and alarm functions.

By pressing the temperature buttons, the display will show the desired temperature settings.

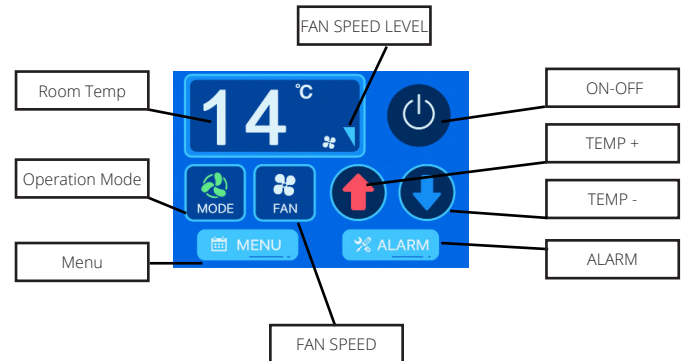



PARAMETER	EXPLANATION
COMPRESSOR	Indicates the current operational status of the compressor. OFF: The compressor is not running; no active cooling or heating is taking place ON: The compressor is running, and the refrigerant is circulating in the system.
PUMP	Indicates seawater pump status. OFF: No seawater flow – system cannot cool or heat. ON: Seawater is circulating.
HEAT	This function applies only to units equipped with electric heating. Electric heating is not available on ESC-SSC-SCP models.
VALVE	Indicates the status of the 3-way valve. OFF in cooling mode, ON in heating mode.
Return temp.	Temperature of air returning from the cabin.
Evaporator temp.	Temperature at the evaporator coil, approximately equal to the air temperature of the fan air.



PARAMETER	EXPLANATION
Condenser	Condenser temp.: Temperature of the condenser
Comp. Current	Real-time compressor current draw in Amps (A)
Temp. Format.	Select between °C and °F display.
Control Fan	Determines whether the fan operation follows the compressor status automatically. OFF: The fan runs continuously, regardless of whether the compressor is active. ON: The fan only runs when the compressor is operating – this allows for more energy-efficient and quieter operation.

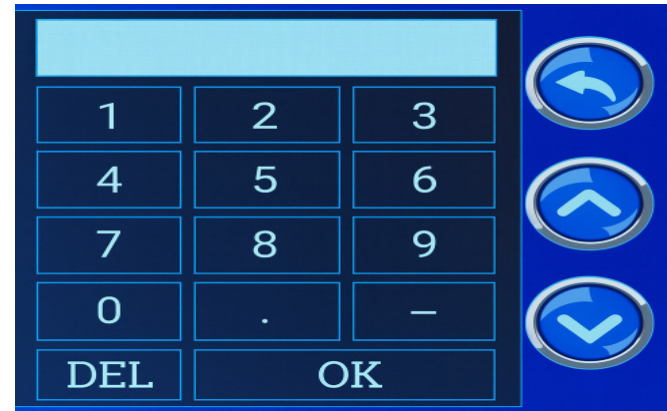

PARAMETER	EXPLANATION
Pram. Settings	Technician-only menu, protected by PIN code.
Bright Adj.	Adjusts screen brightness.



IMPORTANT WARNING:

The PIN-protected menu provides access to fine settings and advanced configuration options of the unit.

We recommend that only qualified personnel make adjustments to factory settings, as improper changes may affect system performance.

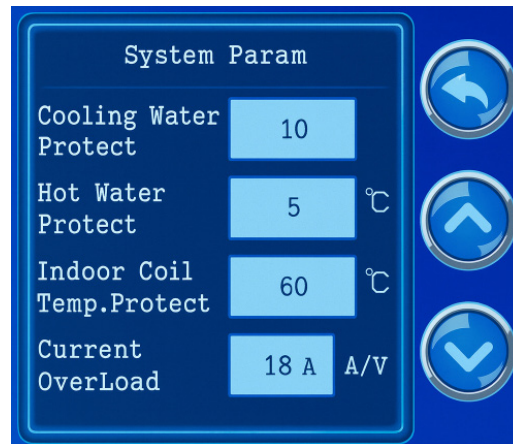
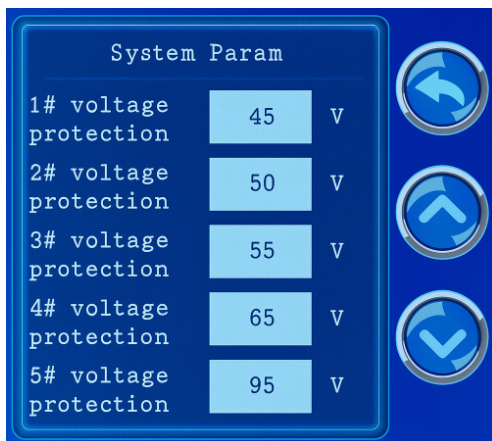

PARAMETER	EXPLANATION
Parameter Settings	The screen displays the fan speed settings in 5 steps.
	Each level can be individually adjusted between 35V and 99V, corresponding to the fan's power output.
	The screen shows the default factory settings.

PARAMETER	EXPLANATION
Cooling Water Protect	This function defines the lower temperature limit for seawater cooling during cooling mode. If the incoming seawater temperature drops below the set value, the unit will automatically stop the compressor to prevent freezing or excessive cooling.
Hot Water Protect	This setting is used in heating mode and defines the minimum allowable seawater temperature (used as the heat source). If the seawater temperature in the condenser approaches the set limit, the system will shut down the heating mode to protect the condenser from freezing. This function also provides protection against potential damage to the condenser caused by excessively cold conditions.



NOTE:

Adjusting the factory fan speed levels may be necessary in the following cases:

- To reduce airflow noise in compact or quiet cabin spaces
- To improve comfort in areas with unique ventilation characteristics.

PART 9. TROUBLESHOOTING

The electronic control of the unit detects possible errors and categories them as follows:

9.1 UNDERSTANDING ERROR CODES

All MBC units are equipped with intelligent control systems that automatically shut down the operation in case of a fault, displaying a specific error code on the controller screen. These error codes help identify the type of malfunction and guide users toward a quick resolution.

Using the table below and the corresponding detailed explanations, the user or installer can determine the cause of the issue and take the appropriate steps to restore normal system operation. Some faults are temporary, while others may require professional intervention.

Please read the descriptions in the table carefully, and only attempt corrective actions if you are confident in the procedure.

ERROR CODE	ERROR DESCRIPTIONS	ISSUE	TREATMENTS	RESUMES
1	Return air temperature sensor error	The temperature sensor is broken	Turn off the system	The device shall restart automatically
2	Evaporator temperature sensor error	The temperature sensor is broken	Turn off the system	The device shall restart automatically
3	Condenser temperature sensor error	The temperature sensor is broken	Turn off the system	The device shall restart automatically
4	Overheated evaporator protection	Compressor stops due to high temperature of evaporator in heating mode	Turn off the system	After resolving the system restarts automatically
5	Coolant leak malfunction	Breakage of gas piping	Turn off the system	Do not use the system, contact a technician
6	Compressor overheating	Coolant leak or faulty water circulation	Turn off the system.	Check sea water flow Check gas in the unit Check the cooling water flow
8	GAS pressure malfunction	Refrigerant high-pressure protection	The compressor turns off	Check the air flow volume Check the gas in the unit
9	Evaporator temperature protection	The evaporator is icing	The compressor turns off	After resolving the defrosting, the compressor restarts automatically
10	Sea water temperature protection	High water temp. in cooling mode Low water temp. in heating mode"	The compressor turns off	Increase the cooling water flow (cooling) Do not use the unit in 7°C sea water degree below (heating)
11	Incorrect connection			A12 & A13 wire connectors are fault Check LAN cable
12	Compressor overcurrent error	The compressor's current draw exceeds max. limit	The compressor turns off	Check the battery voltage The power cable is too thin Check the connections Check the fuse"
15	Communication failure			Check the LAN cable Replace the main board Replace the display"

9.2 ERROR 1 - Room Temperature Sensor Error

The white connector + white slot error is related to an issue where the room

temperature sensor cable connected to the white connector and white slot is disconnected or faulty. This interruption triggers an error message on the display.

Troubleshooting Steps:

- Check the connection between the white connector and the white slot:
- Ensure that the connection is secure and stable.
- Inspect the cables for any damage or disconnection.
- If the cable is damaged or the sensor is faulty:
- Replace the sensor with a new, compatible room temperature sensor.

9.3 ERROR 2 - Evaporator Temperature Sensor Error

The blue connector + blue slot error indicates an issue with the evaporator temperature sensor connected to the blue connector and blue slot. This sensor is responsible for measuring the evaporator temperature.

Most Common Causes:

- Broken wire: If the wire is disconnected, the system detects an infinite OHM value, indicating a malfunction.
- Incorrect connection: The sensor is not properly connected to the main PCB (Printed Circuit Board).

Troubleshooting Steps:

- Inspect the wiring for any damage or disconnection.
- Ensure that the connector is securely attached to the PCB.
- Sensor Replacement
- If the wire is damaged or the sensor is faulty, replace the sensor with a new one.
- Make sure the new sensor is compatible with the system.

9.4 ERROR 3 - Condenser Temperature Sensor Error

The black connector + black slot error indicates a malfunction in the condenser temperature sensor, which is responsible for measuring the condenser's temperature. This sensor is located at the bottom of the condenser.

Most Common Causes:

- Broken wire: If the wire is disconnected, the system detects an infinite OHM value, leading to incorrect readings.
- Incorrect connection: The sensor is not properly connected to the main PCB (Printed Circuit Board), preventing the system from detecting the temperature.

Troubleshooting Steps:

- Check the black connector is securely and correctly connected to the black slot.
- Inspect the wires for any breaks or damage.

Sensor Replacement:

9.5 ERROR 4 – Overheated Evaporator Protection

ERROR 4 occurs in HEAT mode when the evaporator temperature reaches the default 70°C (or a user-defined limit between 50–70°C). To prevent overheating, the system automatically shuts down.

Most Common Causes:

- The compressor will restart automatically once the evaporator cools.
- If this error occurs only once every 20–30 minutes, it is not considered critical.

Recommended Actions:

- Check the air system (intake/supply grilles and ducting) for proper sizing and unobstructed airflow.
- Ensure that air duct length does not exceed 4 meters.
- Avoid undersized supply grilles, which restrict airflow and cause excess heat buildup at the evaporator.
- Follow the installation manual's airflow guidelines.

Solution:

- Perform an air ducting check and adjust grilles or ducts as needed. Proper airflow ensures effective heat dissipation from the evaporator.

9.6 ERROR 5 - Refrigerant Leak Malfunction

ERROR 5 appears when a pressure drop occurs due to a refrigerant leak in the system.

Symptoms and Diagnosis:

- Pressure drop detected in the system.
- Oil in the base tray (typically in cases of severe pressure loss).

Solution:

- A qualified technician is required for troubleshooting and repairs.
- Pressure test with nitrogen: If the leak is significant, the escaping nitrogen will help locate the exact point of leakage.

Leak Detection:

- If the leak is not visible to the naked eye, use a leak detector tool while the system is pressurized with nitrogen to identify the issue.

Repair Process:

- The leak must be sealed by brazing (soldering) the hole to restore system integrity.

System Restoration:

- Repeat nitrogen pressure test to confirm the repair.
- Vacuum the system to remove moisture and air.
- Recharge the system with the specified type and amount of refrigerant.

9.7 ERROR 6 - Compressor Overheating

ERROR 6 is triggered when the clickson (thermal magnetic switch) located on top of the compressor activates. This safety feature prevents the compressor from overheating by shutting it down when temperature or overload conditions become critical, protecting it from potential damage.

Possible Causes:

- Low or Insufficient Refrigerant Charge
- If the refrigerant does not condense properly in the condenser, the system's heat dissipation becomes insufficient.
- This leads to increased pressure and temperature in the condenser, overloading the compressor, causing excessive current draw and overheating.
- Eventually, the clickson is triggered, shutting down the compressor.

Lack of Seawater Circulation

- Insufficient or completely missing seawater flow for condenser cooling is a common cause.
- Dirty or Clogged Condenser
- If the condenser is covered in salt deposits, algae, or debris, water circulation becomes restricted, preventing effective heat dissipation and leading to overheating.

Dirty or Clogged Condenser

- If the condenser is covered in salt deposits, algae, or debris, water circulation becomes restricted, preventing effective heat dissipation and leading to overheating.

Excessive Load or Poor Installation

- The compressor may overheat due to:
- Incorrect system settings.
- Undersized components.
- Extreme external conditions (e.g., excessively high ambient temperature).

Troubleshooting and Solutions:

- Refrigerant Pressure Check:
- Measure the system's refrigerant pressure. If it is low, perform a nitrogen pressure test and leak detection.
- After identifying and repairing leaks, recharge the system with the correct type and amount of refrigerant.

Water Flow Inspection:

- Verify that the water pump is functioning properly and check for blockages or leaks in the system.
- Inspect the seawater filter and heat exchanger, ensuring they are clean and unobstructed.

Reducing System Load:

- Evaluate the installation setup to ensure the system is not overloaded.
- Check that the operating conditions are within the acceptable range for the unit.

Clickson (thermal Switch) Inspection:

- If the error occurs frequently, check the clickson's sensitivity and operation.
- Temporarily bypass the clickson to rule out a faulty sensor. However, only do this for diagnostic purposes—never leave the system running without proper safety protection.

9.8 ERROR 8 - High Gas Pressure Error

ERROR 8 occurs due to high gas pressure and temperature, indicating a disruption in the condensation process. As a result, refrigerant pressure or temperature rises to critical levels, leading to compressor overload and a safety shutdown.

Possible Causes:

- Seawater flow issues, if seawater flow decreases or stops, the condenser cannot dissipate heat properly.
- Refrigerant leak or insufficient refrigerant

Potential Causes of Seawater Flow Issues:

- Malfunctioning or air-locked seawater pump.
- Clogged seawater filter, blocked water intake or piping system.

Insufficient Air Circulation:

- If the fan cannot generate sufficient airflow, the heat exchanger fails to dissipate heat effectively, leading to excessive refrigerant temperature and pressure.

Possible Causes of Insufficient Air Circulation:

- Overly long air ducts (>4 m)
- Increased airflow resistance leads to pressure drops and reduced efficiency.
- Undersized intake and exhaust grilles - If the grilles are too small, the fan cannot circulate enough air, causing the condenser to overheat.

Faulty high pressure sensor

- High pressure sensor In rare cases, the high-pressure
- Sensor may fail, causing a false alarm.

Testing the Sensor:

- Short-Circuit Test: Temporarily short the two sensor wires—if the system restarts, the sensor is faulty.
- Mechanical Sticking: Gently tap the sensor with a screwdriver handle to see if it resets.



WARNING! Shorting the sensor is for testing purposes only! Operating the system without a functional pressure sensor is not recommended.

9.9 ERROR 9 - Evaporator Temperature Protection: DEFROSTING

ERROR 9 indicates the beginning of evaporator icing. To prevent damage, the system automatically activates the Defrosting process, temporarily stopping the compressor. Once defrosting is complete, the system will restart within a few minutes.

Possible Causes:

- Cold sea water temperature:
- When seawater is still cold (barely summer (13-16°C) but the interior temperature of the boat is high, ice formation may occur on the evaporator. This phenomenon disappears in summer as seawater temperatures and air humidity rise up.

Low Refrigerant Level:

- If the issue persists even in hot summer conditions, a refrigerant leak or insufficient refrigerant charge is likely the cause.

Inadequate Airflow:

- Low fan speed, insufficient intake air, or restricted airflow prevents proper heat dissipation from the evaporator, leading to icing.

Undersized Supply Air Grilles:

- If the grilles at the end of the air duct system are too small, cold air cannot escape efficiently, causing frost buildup on the evaporator surface.

9.10 ERROR 10 - Sea Water Temperature Protection

ERROR 10 is triggered when the seawater temperature is too cold (in heating mode) or too hot (in cooling mode). To protect the condenser, the system automatically shuts down if seawater temperature falls below 2-3°C in heating mode or exceeds 35°C in cooling mode.

When Does This Error Occur?

- Sudden mode switching (Heating to Cooling):
- The refrigeration cycle reverses, causing the condenser to act as an evaporator, which the system cannot properly handle.
- This issue is often temporary and may resolve after a restart.

Extreme seawater temperatures:

- Too cold seawater in HEATING mode (7°C or lower).
- Too warm seawater in COOLING mode (35°C or above).

Solutions:

Check seawater conditions:

- Ensure that the seawater temperature is within the specified operating range.

Restart the system:

- A simple restart often resolves the issue.

Proper mode switching:

- Always wait 5 seconds before the transition between heating and cooling is complete on the display.

9.11 ERROR11 - Incorrect Connection

ERROR 11 appears due to a faulty connection between the control unit (PCB) and connectors.

Possible Causes:

- COM1 and DI3 connector issues:
- The connectors are not properly attached to the PCB.
- Damaged LAN cable:
- A faulty or damaged LAN cable may cause data transmission errors.

Solutions:

- Check all connections:
- Ensure that the COM1 and DI3 connectors are securely attached to the PCB.
- Inspect the LAN cable:
- Check for any damage or faults and replace the cable if necessary.
- Restart the system:
- After confirming that all connections are correct, restart the system to clear the error.

9.12 ERROR 12 - Compressor Overcurrent Error

ERROR 12 appears when the compressor's current draw exceeds the specified maximum limit.

Most Common Causes:

- Insufficient Water Circulation - If the condenser does not receive proper cooling, the compressor has to work harder, increasing current draw.

Possible reasons include:

- Faulty water pump
- Clogged seawater filter
- Blocked water system
- Low Shore Power Voltage - If the shore power supply is unstable or too low, the compressor may draw excessive current to compensate. This issue is common in marinas, where power demand is high.

Other Possible Causes

- Refrigerant shortage, leading to excessive compressor load.
- Loose electrical connections or contact issues in power wiring.
- Dirty condenser, which reduces heat dissipation and increases compressor strain.

Troubleshooting and Solutions:

- Check Water Circulation:
 - Ensure the water pump is functioning properly.
 - Clean the seawater filter and check for blockages in the water system.
- Check Shore Power Voltage:
 - Measure the shore power voltage before starting the unit.
 - If voltage is below 200V, use an MBC Soft Starter or try a different power source.

9.13 ERROR 15 - Communication Failure

This error indicates a communication failure between the PCB and the display.

- Solutions:
 - Replace the LAN cable
 - Replace the display
 - Replace the PCB if the issue persists

PART 10. WARRANTY

10.1 MBC Marine – Limited Warranty

MBC Marine provides a limited warranty for its marine air conditioning systems, covering defects in materials and workmanship.

The purpose of this warranty is to ensure the reliable and proper operation of the unit for the original end-user within the defined warranty period.

If a product is found to have a verified defect in material or workmanship during the warranty period, MBC Marine, at its sole discretion, may repair or replace the defective component(s), or refund the purchase price partially or in full.

In the case of a refund, the contractual relationship is considered terminated and no further claims may be made by the owner.

10.2 Warranty Period

The warranty duration is as follows:

For registered units installed by an official MBC partner: 2 years full warranty.

For unregistered units or those not installed by an MBC partner: 1 year (first 6 months include parts and labor; last 6 months cover parts only).

For vessels used for commercial, charter, rental, or other professional purposes, the warranty period is limited to a maximum of one (1) year limited warranty, regardless of product registration status.

The warranty period begins on the date of purchase, the date of installation, or—if part of an OEM installation—the date the vessel is delivered to the end-user. However, under no circumstances shall the warranty period exceed 3 years from the manufacturing date.

The manufacturing date can be verified via the serial number through MBC Marine's customer service.

10.3 Product Registration

To fully benefit from the warranty coverage, product registration is recommended. Registration can be completed online at www.mbc-marine.com. If the product is not registered, a valid proof of purchase must be provided to initiate any warranty claim.



NOTE!

Failure to properly ground and connect the unit to the water system or the electrical system and improper installation work will void the warranty.

MBC Marine reserves the right to reject warranty claims where damage, malfunction, or performance issues are caused directly or indirectly by improper installation.

10.4 Warranty Exclusions

This warranty does not apply in the following cases:

- Normal wear and tear (e.g., filters, fuses).
- Additional labor costs for the removal or reinstallation of the system.
- Damage occurring during transportation or improper storage.
- Improper installation that does not follow official MBC Marine installation guidelines.
- Corrosion, improper maintenance, misuse, or external damage.
- Unauthorized modifications, use of non-genuine parts, or repairs by non-authorized personnel.
- Water damage to electrical components such as control boards or displays.
- Failures due to insufficient winterization.
- Use of unauthorized refrigerant types.
- Any indirect, incidental, or consequential damages (including travel costs, lost time, financial loss, or personal injury).

10.5 Final Provisions

MBC Marine reserves the right to amend this warranty policy at any time without prior notice, especially to comply with national or EU legislation governing warranty rights.

PART 11. KEY INSTALLATION NOTES

- Free airflow – Ensure unobstructed airflow in and out of the unit during installation.
- Seawater system – Follow all seawater system installation guidelines to avoid errors caused by insufficient water flow.
- Always raise one side of the indoor unit by at least 1–2 cm to ensure proper condensate drainage from the drain pan.
- Install the seawater strainer in an easily accessible location, at least 30 cm below the waterline. This helps reduce the risk of airlock and prevents the pump from running dry.
- Drain test – After installation, pour 2–3 liters of water into the drain pan to verify that the condensate drains properly. Observe the flow to ensure there are no blockages or backflow.
- Do not share the seawater circuit with other systems (e.g. toilet or engine cooling). Doing so can cause serious flow issues and system error codes
- Install a zinc or aluminum sacrificial anode upstream of the pump to protect the condenser and other metal components from electrolysis and corrosion.
- Connect all metal parts in contact with seawater to the boat's grounding system, including the seawater inlet fitting, the pump, and the chassis of the air conditioning unit.
- Avoid 90° or 180° bends in the air ducting, as these can reduce airflow by up to 25%.
- Do not install the display in direct sunlight, near heat sources, or in walls with heat behind them. Improper placement can cause inaccurate temperature readings.
- Errors related to refrigerant pressure and temperature (e.g. ERROR 8, ERROR 10) are often caused by insufficient seawater flow or pump failure — always check the seawater system first.

PART 12. TECHNICAL DATA

TECHNICAL PARAMETERS OF THE A/C UNIT		ESC 08	ESC 10	ESC 13	ESC 16	ESC24
Cooling capacity	Btu/h	8000	10000	13000	16000	24000
Heating capacity	Btu/h	8700	11000	13800	17600	26400
Power supply	230V/50-60Hz 1 Ph					
Power Input (kW)	Cooling	0,74	0,78	1,01	1,17	1,75
	Heating	0,86	1,05	1,28	1,56	2,2
Load Amps (A)	Cooling	3,3	3,5	4,2	5,1	7,9
	Heating	3,7	4	5,2	6,5	9,9
Ventilation (m3/h)	High	420	500	580	730	1200
	Medium	350	405	495	610	1080
	Low	280	350	410	520	900
Refrigerant type	R32					
Sizes	Height	320	322	350	360	430
	Width	420	500	500	510	690
	Depth	255	305	305	320	449
Size of air duct (mm)	100	125	125	150	200	
Size of return air grills (cm2)	300	450	450	510	720	
Sizes of supply air grills(cm2)	750	800	800	1030	1400	
Drain water outlets	DN20	DN20	DN20	DN20	DN20	
Size of condenser's water connection	5/8"	5/8"	5/8"	5/8"	5/8"	
Weight (kg)	20	25,5	26,5	29,5	58	

PART 13. LEGAL DISCLAIMERS AND LIABILITY

MBC Marine has prepared this installation and user guide based on the most current information available.

However, due to the nature of its use, the guide does not cover all possible user needs or questions.

We recommend contacting our experts for any specific inquiries or unique requirements.

While every precaution has been taken to ensure the accuracy of this guide, MBC Marine is not liable for any errors or omissions, nor for any damages arising from the proper or improper use of the product or the information provided herein.

No part of this publication may be reproduced, translated, stored in a retrieval system, or transmitted in any form or by any means, whether electronic, mechanical, photocopying, recording, or otherwise, without prior written permission from MBC Marine.

CE MANUFACTURER'S DECLARATION OF CONFORMITY

Name and address of manufacturer:
MBC Marine Ltd., Petőfi Sándor 39/A Díósd, 2049
 08 November 2019.

We hereby certify that the designing and manufacturing of

Marine air conditioning units

were performed in accordance with the following specifications of the following standards:

EN 55014-1 2011/65/EC (RoHS), EN 55022, EN 55024,, EN 61000, EN 60950-1,
 EN 301 489-1, EN 301 489-18.

According to the above, the product :

Marine air conditioner: **ESC08 - ESC10 - ESC13 - ESC16 - ESC24**
SCP13 - SCP16 - SCP24

CONFORMS

to the specifications of standards and directives and to the conditions of healthy and safe use indicated below:

NUMBER, ABBREVIATED NAME OF DIRECTIVE	TITLE
EN 55014-1	Electromagnetic compatibility. Requirements for household appliances, electric tools and similar apparatus. Part 1: Emission
EN 61000-3-2	Electromagnetic compatibility (EMC). Part 3-2: Limits. Limits for harmonic current emissions (equipment input current ≤16 A per phase).
EN 61000-3-3	Limitation of voltage changes, voltage fluctuations and flicker in public low-voltage supply systems, for equipment with rated current ≤16 A per phase and not subject to conditional connection
IEC 61000-4/2/3/4/5/6/11	Electrostatic discharge, radiated electromagnetic field, electrical fast transients, surge immunity, conducted disturbances, voltage dips immunity.
2011/65/EC (RoHS)	Use of certain hazardous substances in electrical and electronic equipment

Manufactured and marketed fixture conform to the specifications indicated above as the following:

PRODUCT FEATURES	RESULT	TESTING/EVALUATION METHOD
Disturbance power emission	Pass	EN 55014-1
Harmonic current emission	Pass	EN 61000-3-2:2006 + A1: 2009 +A2:2009
Voltage fluctuations and flicker	Pass	EN 61000-3-3:2008
Electrostatic discharge, radiated electromagnetic field, electrical fast transients, surge immunity, conducted disturbances, voltage dips immunity.	Pass	IEC 61000-4-2/3/4/5/6/11
Hazardous substances contents	Pass	Chemical quantitative analysis

These directives apply to full compliance with the installation and operating instructions issued by MBC Marine.

The data here in above are verified by:
MBC Marine Ltd., Petőfi Sándor 39/A Díósd, 2049

Last two digits of the year of CE marking: **19**

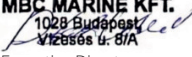
MBC MARINE KFT.
 1028 Budapest
 Vízvári ú. 8/A

 Executive Director

